

# ***TPA1517NE***

## ***Audio Power Amplifier***

### ***Evaluation Module***

---

---

---

DATA MANUAL: SLOU007

*Date: July 1997*



## IMPORTANT NOTICE

Texas Instruments and its subsidiaries (TI) reserve the right to make changes to their products or to discontinue any product or service without notice, and advise customers to obtain the latest version of relevant information to verify, before placing orders, that information being relied on is current and complete. All products are sold subject to the terms and conditions of sale supplied at the time of order acknowledgement, including those pertaining to warranty, patent infringement, and limitation of liability.

TI warrants performance of its semiconductor products to the specifications applicable at the time of sale in accordance with TI's standard warranty. Testing and other quality control techniques are utilized to the extent TI deems necessary to support this warranty. Specific testing of all parameters of each device is not necessarily performed, except those mandated by government requirements.

CERTAIN APPLICATIONS USING SEMICONDUCTOR PRODUCTS MAY INVOLVE POTENTIAL RISKS OF DEATH, PERSONAL INJURY, OR SEVERE PROPERTY OR ENVIRONMENTAL DAMAGE ("CRITICAL APPLICATIONS"). TI SEMICONDUCTOR PRODUCTS ARE NOT DESIGNED, AUTHORIZED, OR WARRANTED TO BE SUITABLE FOR USE IN LIFE-SUPPORT DEVICES OR SYSTEMS OR OTHER CRITICAL APPLICATIONS. INCLUSION OF TI PRODUCTS IN SUCH APPLICATIONS IS UNDERSTOOD TO BE FULLY AT THE CUSTOMER'S RISK.

In order to minimize risks associated with the customer's applications, adequate design and operating safeguards must be provided by the customer to minimize inherent or procedural hazards.

TI assumes no liability for applications assistance or customer product design. TI does not warrant or represent that any license, either express or implied, is granted under any patent right, copyright, mask work right, or other intellectual property right of TI covering or relating to any combination, machine, or process in which such semiconductor products or services might be or are used. TI's publication of information regarding any third party's products or services does not constitute TI's approval, warranty or endorsement thereof.

## ***About This Manual***

The purpose of this document is to serve as a reference manual for the TPA1517NE 6 Watt/Channel Stereo Audio Power Amplifier Evaluation Module (SL0P105). This document provides information on the optimal setup and operation of this product.

## ***How to Use this Manual***

This document contains the following chapters:

### ***Chapter 1***

#### ***Overview***

A general description of the TPA1517NE, its key features, operating specifications, and design notes.

### ***Chapter 2***

#### ***Hardware***

A description of the TPA1517NE, hardware including board schematic, connections, layout and bill of materials.

***If You need Assistance...***

<b>If You Want to...</b>	<b>Do This...</b>
Request more information about Texas instruments Mixed Signal Products	Call the PIC† hotline: <b>(972) 644-5580</b>  or send a fax to the PIC: <b>(972) 480-7800</b>  or write to: Texas Instruments Incorporated Product Information Center, MS 3123 P.O. Box 660246 Dallas, Texas 75266
Order Texas Instruments documentation	Call the PIC† hotline: <b>(972) 644-5580</b>
Ask questions about product operation or report suspected problems	Call the PIC† hotline: <b>(972) 644-5580</b>
Report mistakes in this document or any other TI Mixed Signal Products documentation	Send a fax to MSP Marketing Documentation Correction: <b>(214) 480-3160</b>  or send your comments to: Texas Instruments Incorporated MSP Marketing Documentation Correction, MS 8710 P.O. Box 660199 Dallas, Texas 75266-0199

† Texas Instruments Product Information Center

# Contents

1. Quick Start .....	6
1.1 Introduction .....	7
1.2 Layout Definition .....	7
1.3 Operation Notes .....	8
2.1 Schematic .....	10
2.2 Input/Output Connections .....	11
2.3 Controls.....	12
2.4 Layout .....	13
2.5 Bill of Materials .....	15

## Figures

FIGURE 1. TPA1517NE COMPONENT PLACEMENT .....	7
FIGURE 2. TPA1517NE EVM SCHEMATIC .....	10
FIGURE 3. INPUT/OUTPUT CONNECTIONS.....	11

## I. Quick Start for P-N-P Kit

Included below is a quick checklist of setup steps to get the TPA1517NE up and running fast.

1. Set S1 to the “off” position.
2. Align the TPA1517NE with socket U2, such that the side with 4 pins is adjacent to socket U1, and firmly connect it to the P-N-P board.
3. Check the power supply jumper setting on the P-N-P board. To use battery power select JP3, to select wall mount AC/DC power select JP2, or to use a bench type DC power supply select JP1  
**Note: be sure only one of these three jumpers is connected by a shorting block.**
4. Check the mode/mute jumper circuitry (JP6, JP7, JP8). To begin with, set JP7 to Lo, JP8 to Lo and JP6 to Mute. This arrangement causes the TPA1517NE to be active when no headphones are present. In the future refer to Table 1 in the P-N-P board Application Report (SLOU001) to adjust these settings.
5. Check the Audio Input Path Selection Circuitry, if there is no EVM present in U1, then set S2 to the “off” position
6. Set S3 to the “U5” position (only if U5 EVM is present).
7. Connect a mono audio source to either J3 or J5 (or both), or connect a stereo audio source to J4.
8. Connect a 4 or 8 ohm speaker(s) to either (or both of) the RCA jacks at J7 and J9 or to the wire clips at J8.
9. Connect your power supply to the P-N-P board.
10. Push S1 to the “on” position, and activate your audio source.

Step 10 will activate the EVMs present on the P-N-P. If you do not hear sound, please consult the troubleshooting section of the P-N-P Board application report (SLOU001).

## 1.1 Introduction

The TPA1517NE EVM (SLOP105) is designed to provide the circuitry required to evaluate the TPA1517NE performance without having to invest in PCB layout or assembly. Refer to the application note in the TPA1517 data sheet (SLOS162A) for a description of the circuit configuration and selection of components.

## 1.2 Layout Description

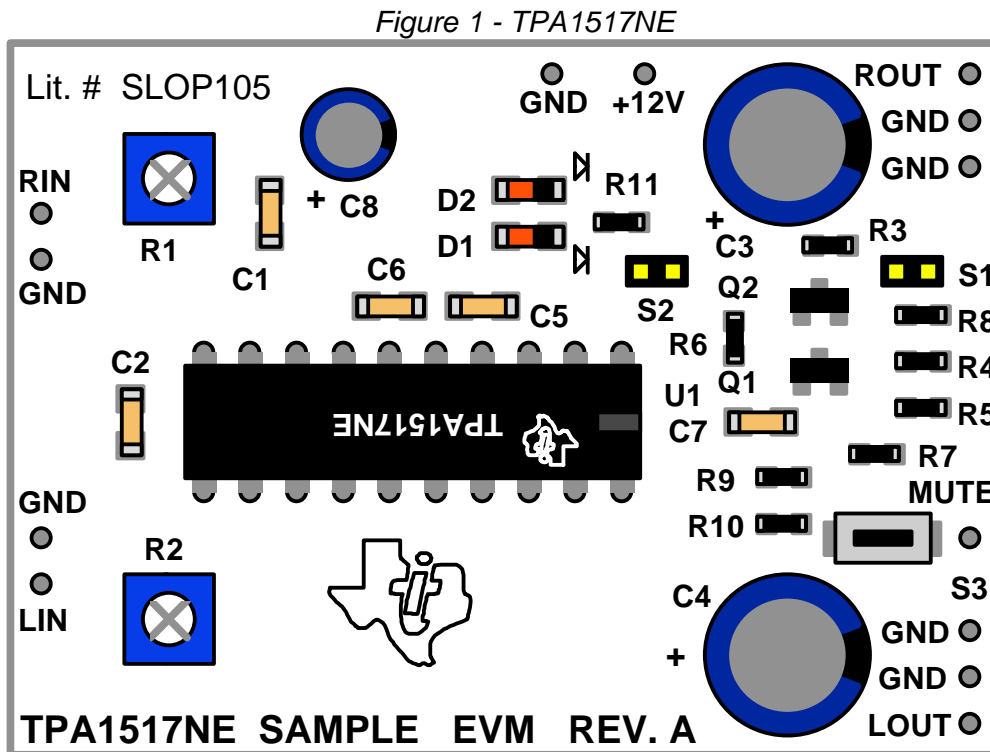



U1 - TPA1517NE  
stereo 5 W Audio Amplifier



C1, 2, 6, 7 - Capacitor, 1.0  $\mu$ F, Ceramic

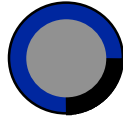

C3, 4 - Capacitor, 470  $\mu$ F 16 V Alum Elect



C5 - Capacitor, 2.2  $\mu$ F, Ceramic



C8 - Capacitor, 100  $\mu$ F, 25 V Alum Elect



R1, 2 - Potentiometer, 50 k $\Omega$ , 3/4 Turn



R3, 4, 9 - Resistor, 10 k $\Omega$  Carbon



R5, 6 - Resistor, 47 k $\Omega$  Carbon



R7, 10 - Resistor, 1 k $\Omega$  Carbon



R8, - Resistor, 6.8 k $\Omega$  Carbon



R11 - Resistor, 220  $\Omega$  Carbon



S1, 2, - Jumper



S3, - Switch, Norm Open, Momentary

### 1.3 Operation Notes

The TPA1517NE EVM (SLOP105) was designed to plug into TI's P-N-P Audio Evaluation Platform (SLOP097). Slot U2 on the P-N-P also is compatible with the TPA1517DWP EVM. No soldering is required for use in the P-N-P system. Standard speaker jacks, RCA jacks and 1/8" headphone jacks are provided on the P-N-P for quick and easy evaluation of all TI audio power amplifiers. The TPA1517 is designed to drive 4 ohm speakers up to 6W.



The connection pins of the TPA1517NE EVM are on a 0.1" grid for easy interface to standard plugboard based prototype systems.

The Thermal layout of the EVM is important. Linear Audio Power Amplifiers dissipated large amounts of heat during operation. The data sheet for the TPA1517 (SLOS162A) details heat dissipation for 12 and 14.5 volt operation. The 20-Pin DIP NE package has a special internal design where pins 10 through 20 are thermally connected to the chip. These pins must then be thermally connected to as much copper areas as possible on the surface of the PCB or to internal ground planes. Special consideration should be given to the thermal layout due to the effect on maximum ambient temperature operation. Copper area on the surface should then be connected to the ground plane layer by vias. The vias should not use WEBed connections but should have a solid connection to the copper areas. The solid connections make a much better thermal connection.

2.1 Schematic



# TPA1517NE EVM Circuit SLOP105

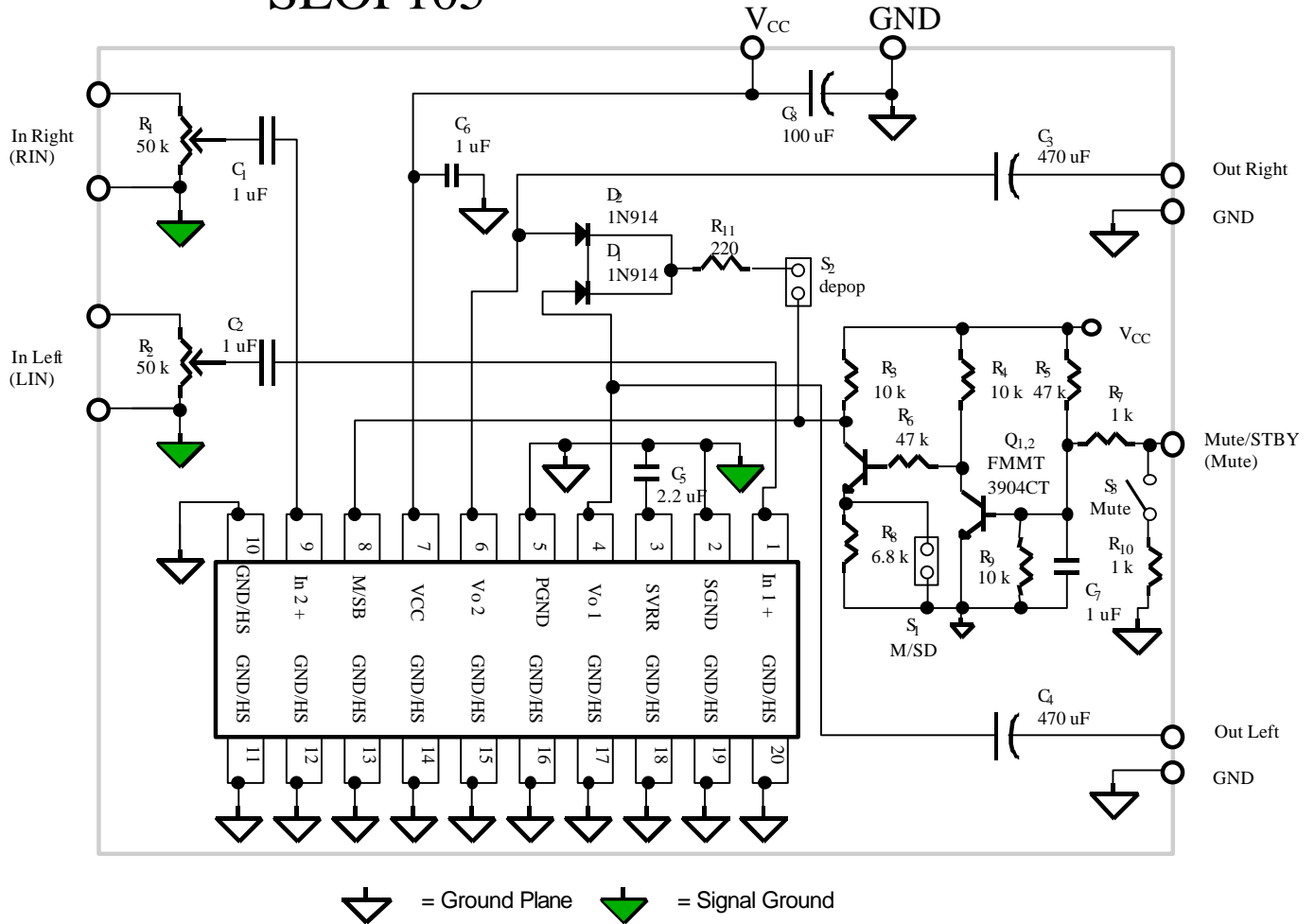

Figure 2 - Schematic of 1517NE EVM

Power: 9.5 to 15 Vdc, 2.5 A peak, 0.5 A rms (Normal Music Input).

Audio Inputs: Stereo, Cap Coupled

Speaker Outputs: 4 ohm drive, 3 W rms/Channel (Tone Output)  
8 ohm drive, 1.5 W rms/Channel (Tone Output)

## 2.2 Input/Output Connections

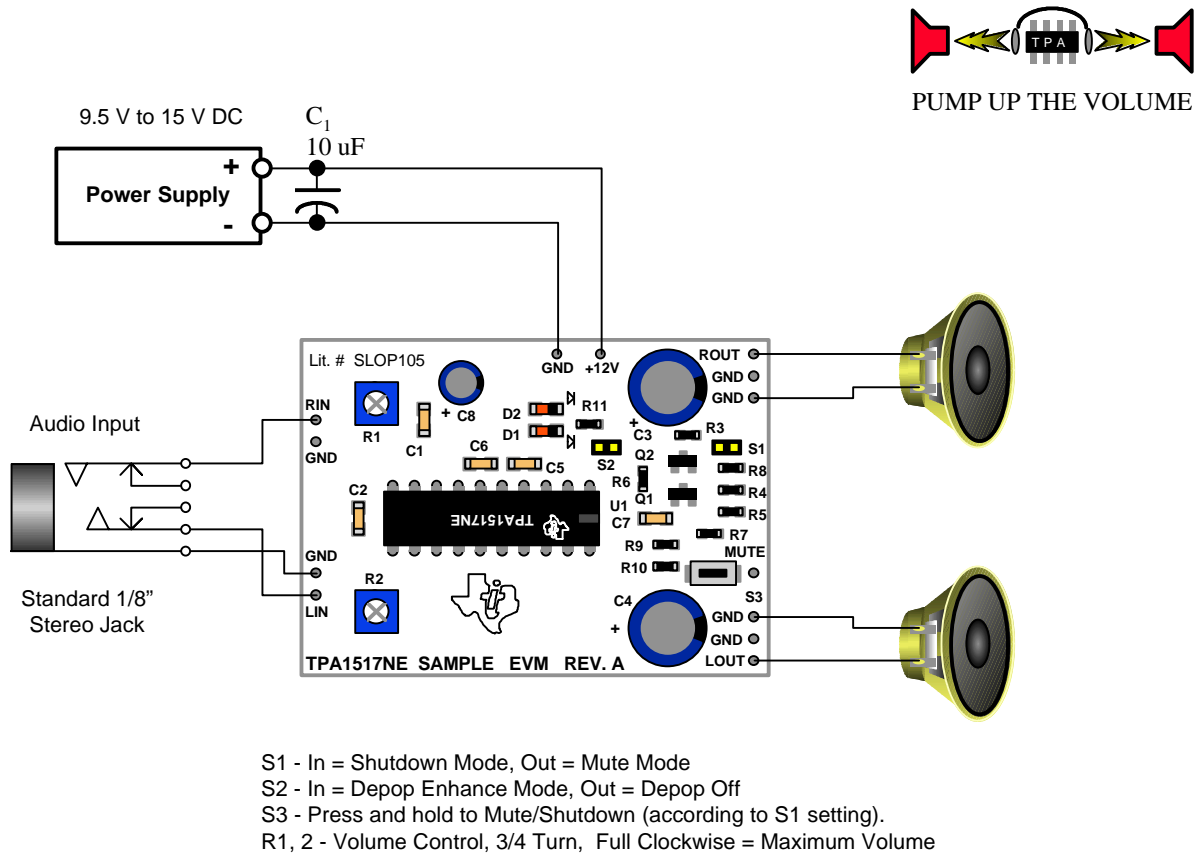

04/19/97

Figure 3. EVM Connections Diagram

The connections diagram shows a stereo output drive system using the TPA1517NE EVM (SLOP105) configured to drive stereo speakers. A standard 1/8" stereo input jack is shown providing a convenient connection to CD players or other commercial sources of audio signals.

### Key Features:

The key features of the system are:

- 1) Stereo Single Ended (SE) drive of 4 ohm or 8 ohm speakers. The input and output coupling capacitors are included on the EVM making connections very simple.
- 2) Mute of the Speaker Drive - Either pressing the Mute switch or providing an external TTL control of the Mute input allows one to mute the speaker output.
- 3) The special DIP NE package is thermally connected the PCB ground plane for enhanced thermal performance.

---

## 2.3 Controls

Mute/Standby Select - S1: Jumper in place sets low current standby mode. Jumper out sets mute mode. Mode is activated by Switch S3 or external TTL input at Mute input.

Depop Select - S2: Jumper in place selects enhanced Depop mode. Jumper out disables depop circuitry.

Mute Input/Switch - S3: Low activates mute/standby (S1) circuitry. Switch S3 is a momentary action push button. Press S1 to mute.

R1/R2 Gain Control Pots: 3/4 turn adjusts amplifier Volume. Clockwise increases volume.

The M/SB pin of the IC (PIN 8) operates over a range of voltages. 2 volts is standby mode, 3.4 to 8.8 volts is mute mode and 9.2 to Vcc is operate mode. Transistors Q1 and Q2 form a network to allow TTL control of the M/SB function. S1 determines the active voltage range of the transistor circuit into M/SB. When S1 is in place transistor Q2 pulls M/SB to 0 volts (Standby mode), when S1 is out, resistor R8 forms a divider network with R3 to set the voltage in the Mute range. Typically mute mode pop noises are not as loud as standby mode pops.

Diodes D1 and D2 when enabled by S2 allow the charge on the output coupling caps to drain during standby mode. This helps reduce pop noises when returning to operating mode.

## 2.4 Layout

**NOTE:** Layouts are not to scale.

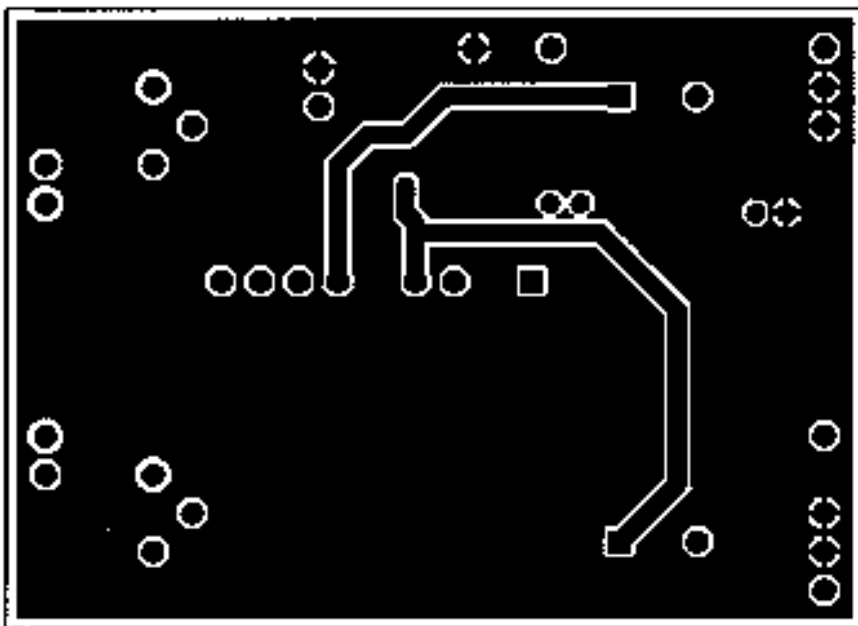
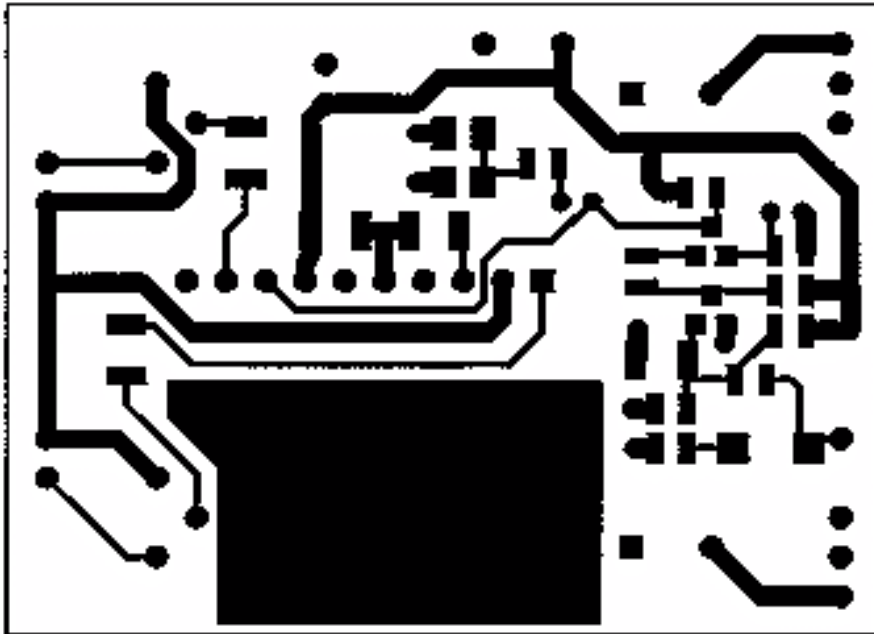

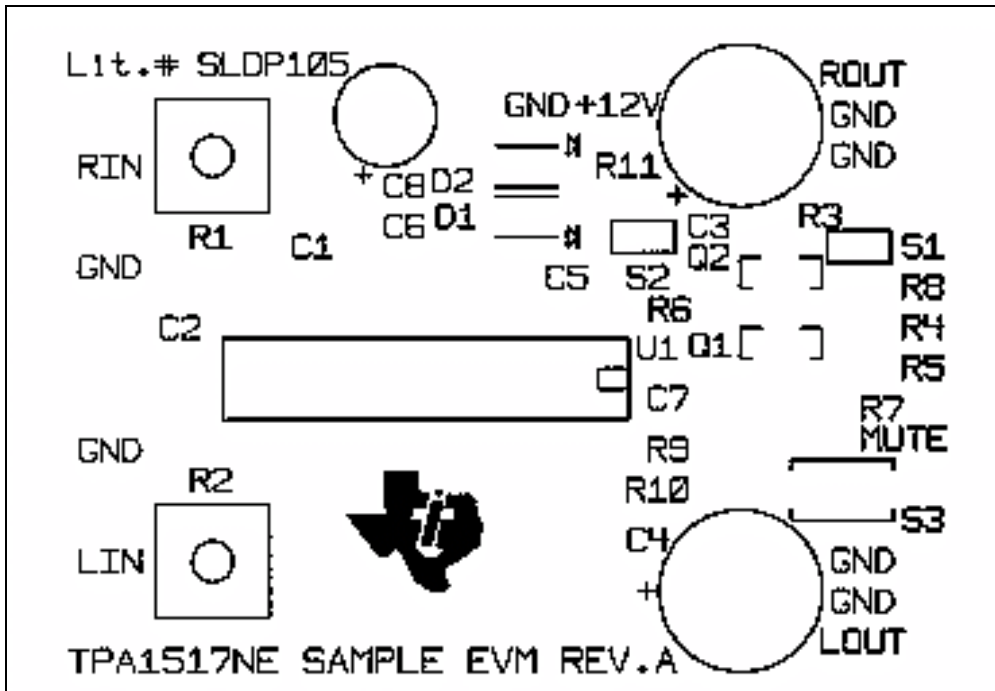

**NOTE:** Layouts are not to scale.

## 2.5 Bill of Materials

DESCRIPTION	REF.	MANUFAC.	DIGI KEY	PCBA
	DESIG.	PART NUMBER	PART NUMBER	Qty
CAP., 1.0UF, +80/-20%, NON POLARIZED, SMD SIZE 1206	C1,C2,C6, C7	(MURATA) GRM42-6Y5V105Z16BL	(NEWARK) 93F2254	4
CAP., 2.2UF,20%, NON POLARIZED, SMD SIZE 1206	C5	(TDK) C3216X5R1A225		1
CAP, 470UF, +80/-20%,16VDC, ALUMINUM ELECTROLYTIC, XXMM DIA,7MM CTRS.	C3,C4	(PANASONIC) ECE-A1CF471	(DIGI-KEY) P6708-ND	2
CAP, 100UF, +80/-20%,16VDC, ALUMINUM ELECTROLYTIC ,10MM DIA,5MM CTRS.	C8	(PANASONIC) ECE-A1CF101	(DIGI-KEY) P6705-ND	1
POT., 50 K OHM, 1/2W, 20%,THRU HOLE	R1,R2	(BOURNS) 3323P SERIES 50K	(DIGI-KEY) 3323P-503-ND	2
RES., 10 K OHM, 1/10W, 5%, SMD, SIZE 0805	R3, R4, R9	(PANASONIC) ERJ-6GEYJ103V	(DIGI-KEY) P10KABK-ND	3
RES., 1 K OHM, 1/10W, 1%, SMD, SIZE 0805	R7, R10	(PANASONIC) ERJ-6GEYJ102V	(DIGI-KEY) P1.00KCCT-ND	2
RES., 47 K OHM, 1/10W, 5%, SMD, SIZE 0805	R5, R6	(PANASONIC) ERJ-6GEYJ473V	(DIGI-KEY) P47KABK-ND	2
RES., 6.98 K OHM, 1/10W, 1%, SMD, SIZE 0805	R8	(PANASONIC) ERJ-6GEYJ698V	(DIGI-KEY) P6.98KCCT-ND	1
RES., 220 OHM, 1/10W, 1%, SMD, SIZE 0805	R11	(PANASONIC) ERJ-6GEYJ221V	(DIGI-KEY) P221CCT-ND	1
SWITCH, MOMENTARY, SMD	S3	(PANASONIC) 8048SCT-ND or EVQ-PJS04K	(DIGI-KEY) P8048SCT-ND	1
HEADER, 1X2,2MM CTRS.	S1,S2	(NORCOMP)	(DIGI-KEY) 2163-02-ND	2
SHUNTS, 2MM	P1	(3M)	(DIGI-KEY) 953170-30-ND	1
TRANSISTOR, FMMT3904CT,SMD,S0T-23	Q1,Q2	(ZETEX) FMMT3904CT-ND	(DIGI-KEY) FMMT3904CT-ND	2
DIODE, LL4148CT-ND, SMD, PACKAGE DL-35	D1,D2	LL4148CT-ND	(DIGI-KEY) LL4148CT-ND	2
IC., TPA1517NE, AUDIO AMPLIFIER, 2 CHANNEL,20 PIN DIP	U1	(TI) TPA1517NE		1
PCB, TPA1517NE SAMPLE EVM	PCB1	(COMPURROUTE) TOOL #008451		1